

INDIVIDUAL SPECIFICATION SHEET

Product Name: 塑封方形慢断300V FUSE

Part Number: SQT8.00M

Revision: B



Dongguan TLC Electronic Technology Co., LTD

No.18,5th GaoLi Road,TangXia Town,DongGuan,GuangDong,P.R China 523710

TEL: 86-0769-3892 0511

FAX: 86-0769-8793 2077

Http: www.tlcet.com.cn

Rev.	Effective Date	Changed Contents
A	2020-4-11	New release
B	2021-10-27	取消安规认证符号

☞ The individual specification sheet are the property of Dongguan TLC electronic technology Co.,Ltd and shall not be copied or used as commercial purposes without permission.

PREPARED BY

杨娟

APPROVED BY

杨娟

SQT***M 系列(300V 慢断)保险丝规格书

1. 適用範圍 Scope of application

本產品適用於各種電子產品的電路中起過電流保護作用.

This product is suitable for various kinds of electronic machines to work for over current protection.

2. 相關標準及認證 Relevant Standards and Certification

2.1 執行標準 Standards : IEC60127-3 GB/T9364.3

3. 結構及尺寸 Structure and Size (unit: mm)

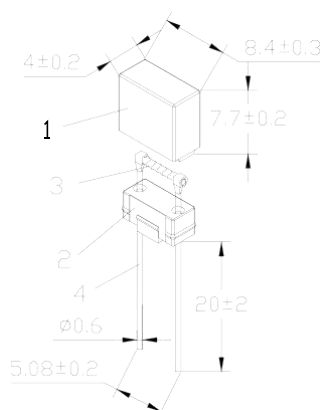

4. 材料明細 Material Details

編號 No.	零件名稱 Part Name	材質 Material
①	外殼 Case	PA66 (UL94-V0)
②	基座 Base	PA66 (UL94-V0)
③	熔絲 Fuse element	合金線 Alloy
④	引線 Lead wire	鍍錫銅線 Tinned copper wire

5. 標示 Marking

保險絲應有下列標示 The fuse shall have the following marking :

竟沃標誌 Hcd logo : 
 延時符號 Time-lag Symbol : T
 額定電流 Ampere rating : 8A
 額定電壓 Voltage rating : 300V
 系列号 / Series No.: SQT

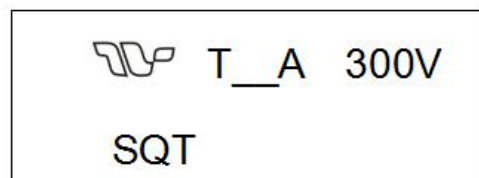

注意：对标示的大小和位置没有规定

Note : Size and position of the markings shall not be provided.

6.外觀 Appearance

6.1 外觀不應有顯著的污點、裂紋。

There shall not be any remarkable stain, rust or crack on the appearances.

6.2 標示應該很容易辨識。

Marking shall be easily legible.

7.機械特性 Mechanical characteristics

拉力強度試驗 Tensile test

將保險絲固定好後，對保險絲引線施加 10N 的拉力，持續 1 分鐘。試驗過後，保險絲沒有任何破損現象。

Exert the axial pulling force of 10N to the both ends of lead wire for 1 minute. After the test the fuse shall be no damage and loosening.

8. 电压降 (Voltage Drop)

熔断体在额定电流条件下,两端的电压降不应超过下表规定的最大值。

The voltage drop across the fuse-link at their rated current shall not exceed the maximum values is in Follows.

产品型号 Model	额定电流 Rated Current	额定电压 Rated Voltage	最大电压降 Maximum Voltage Drop(mv)	分断能力 Breaking Capacity
SQT8.00M	8A	300VAC	100	100A300V AC

9.電氣特性 Electrical characteristics

9.1 實驗條件 Test condition

所有測試環境溫度為 $25\pm 5^{\circ}\text{C}$ 。

All electrical characteristics tests are conducted at an ambient temperature of $25\pm 5^{\circ}\text{C}$.

9.2 分斷能力 Interrupting rating test

保險絲能承受的分斷能力：35A 或 10 倍的額定電流當中較大的。分斷能力測試後測得保險絲的絕緣阻抗值大於 $0.1\text{M}\Omega$ 。

The fuse interrupting capacity：35A or 10 times the rated current whichever is greater. After interrupting, the insulation resistance between the fuse terminations shall be not less than $0.1\text{M}\Omega$.

9.3 溫度上升試驗 Temperature Rising Test

通 1.5 倍額定電流 15 分鐘，然後每隔 15 分鐘增加 0.1 倍額定電流。測得保險絲斷開時任何部位的溫升不得超過 135°C ，周圍環境溫度為 $25\pm 5^{\circ}\text{C}$ 。

注：溫度上升 = 保險絲表面的溫度 - 環境溫度

Temperature Rising Test: The rated current of 1.5 times is applied for 15 minutes. After the first 15 minutes, the current is increased by 0.1 times the rated current every 15 minutes until the fuse operates. The temperature rising on the fuse surface is not higher than 135°C .

Note: Temp. rise = Fuse temp. - Ambient temp.

9.4 時間-電流特性 Time-Current Characteristics

額定電流的% % of ampere rating	熔斷時間 Opening time
150%	1H Min
210%	2 min Max
275%	400 ms~10 s
400%	150 ms~3 s
1000%	20 ms~150 ms

9.5 耐久性測試 Endurance test

對保險絲通過相關標準規格單規定的額定電流 1 小時,然後截斷電流 15 分鐘,將該循環重複 100 次。試驗過後保險絲沒有任何破損現象。

A ampere rating specified in the relevant standard sheet is passed through the fuse for a period of 1h.The current is then switched off for a period of 15 minutes. This cycle is repeated 100 times. After the test the fuse shall be no damage and loosening.

9.6 焊接參數 Soldering parameters

9.6.1 波峰焊 260°C,最大 10 秒,

Wave soldering 260 °C,10 sec. Maximum

9.6.2 手工焊 370°C,最大 5 秒,

Manual soldering 370°C, 5 sec. Maximum

9.6.3 焊錫溫度曲線圖 Soldering Profile

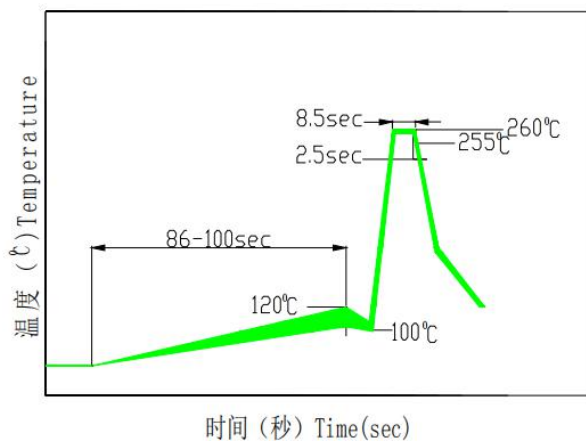

C

9.7 溫度折減曲線 Temperature derating curve

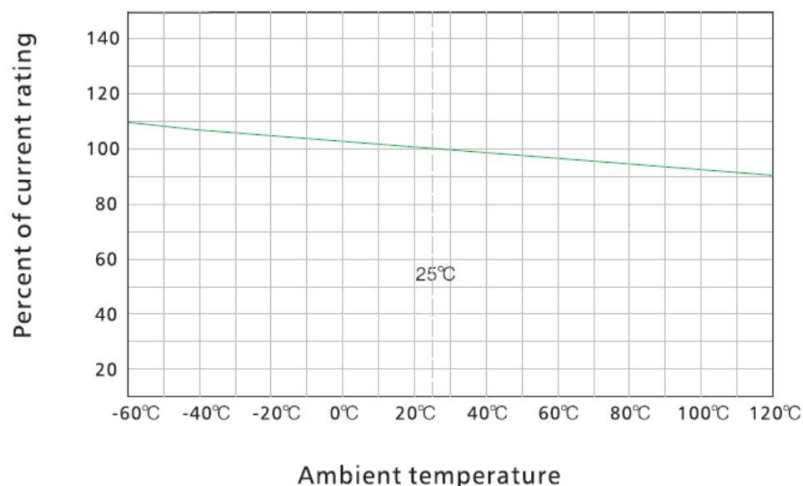

9.8 分斷能力 Breaking Capacity

保险丝分断电路后，方形塑料帽不应飞脱、损坏。防爆性能要求系按贵司指定要求生产。
after this test, there shall be not damaged or shattered of the square thermoplastic cap.

10. 環境特性 Environmental characteristics

10.1 使用溫度範圍 Operating Temperature

-55°C ~ 125°C。

10.2 保存條件 Storage Conditions

相對濕度 ≤ 75%，可存放 3 年。

Relative humidity ≤ 75%, store 3 years .

11. 包裝 Packing

11.1 500PCS/小袋、4 小袋/內盒、10 內盒/外箱(實際裝箱依客戶訂單)。

500 fuses per plastic bag, 4 plastic bags per inner box, 10 inner boxes per external carton. (The actual case in accordance with the customer order)

11.2 產品符合 RoHS 環保指令

The product is compliant with RoHS Directive

11.3 包裝尺寸 Package Size

Inner Packaging Box

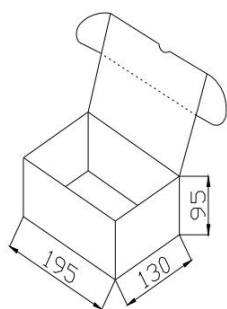

Master Carton

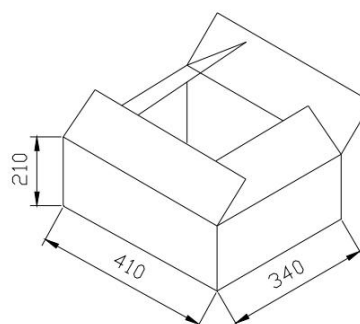

Qty Per Box	2000pcs	Qty Per Carton	20000pcs
-------------	---------	----------------	----------